

DPS5000

Digital Pressure Sensing Platform

The new DPS5000 from GE, part of the UNIK5000 family, offers integrated digital electronics to enhance the performance level of the UNIK 5000 Pressure Sensing Platform to levels unmatched by traditional analogue sensors. It features an I2C digital interface, over which fully compensated readings of Pressure and Temperature are sent, as well as control of many functions of the device.

High Quality

With 40 years of pressure measurement experience, our field-proven Druck technology is at the heart of the new platform, resulting in a range of high quality, high stability pressure sensors.

Bespoke as Standard

Custom-built from standard components, manufacturing sensors to your requirements is fast and simple; each UNIK 5000 is a “bespoke” pressure sensing solution, but with the short lead times and competitive pricing you would expect from standard products.

Expertise

We have the people and the knowledge to support your needs for accurate and reliable product performance; our team of experts can help you make the right sensor selection, guiding you and providing the help and tools you need. It is important that you ensure that the sensor materials and performance selected are suitable for your application.



Features

- Ranges from 70 mbar to 100 bar
- Total accuracy to ± 0.1 % FS
- Stainless steel construction
- 3 V supply voltage
- Low power
- I2C digital output
- Sleep mode
- Hazardous area certifications
- Excellent long-term stability

DPS5000 Specifications

Operating Pressure Ranges

Gauge Ranges

Zero-based ranges:

- 70 mbar
- 200 mbar
- 350 mbar
- 700 mbar
- 1 bar
- 2 bar
- 3.5 bar
- 7 bar
- 10 bar
- 20 bar
- 28 bar
- 35 bar
- 70 bar
- 100 bar

Absolute Ranges

- 0.8 to 3 bar
- 1 to 7 bar
- 2 to 12 bar
- 3 to 28 bar
- 5 to 40 bar
- 10 to 70 bar
- 18 to 90 bar
- 15 to 100 bar

Over Pressure

2 × pressure range for absolute ranges

4 × pressure range for gauge ranges

Containment Pressure

6 × pressure range for gauge ranges (200 bar maximum)

200 bar for absolute ranges

Supply

Supply voltage

2.7 to 3.6 Vdc

Current consumption

<50 µA Standby

<2 mA average during acquisition

Output/Communications

I2C Slave Device, 100 kHz maximum data rate

Power-on Time

30 ms to acquisition from standby

Insulation Resistance

500 Vdc ≥ 100 MΩ

Performance

Pressure Performance

Calibrated accuracy over the calibrated temperature range including zero and span setting and the effects of non-linearity, hysteresis and repeatability

Gauge Reference

±0.1 % FS

Increases pro-rata for pressure ranges below 700 mbar

Absolute Reference

±0.2 % of reading (RDG)

Temperature Performance

Accuracy over the calibrated temperature range ±3°C

Long Term Stability

±0.05 % FS /year typical

±0.1 % FS maximum at reference conditions

Increases pro-rata for pressure ranges below 700 mbar

Physical Specifications

Environmental Protection

Internal version – Not applicable

External version – IP68 to 700 mH₂O

Operating Temperature Range

-40°C to +85°C (-40°F to +185°F)

Pressure Media

Fluids compatible with stainless steel 316L and Hastelloy C276

Statement in accordance with the European Pressure Equipment Directive

Refer to document K0581 for product classification and regulatory information

Enclosure Materials

Stainless steel (body)

Pressure Connectors

PA G1/4 female

PB G1/4 male flat

PE 1/4 NPT female

PF 1/4 NPT male

PG 1/8 NPT male

Other connectors may be available. Contact BHGE to discuss your requirement.

Electrical Connector

| Option Code | Description | IP rating |
|-------------|---------------------|-------------------------------|
| 0 Internal | None (flying leads) | - |
| 3 External | Polyurethane cable | IP68 to 700 mH ₂ O |

Wiring Details

| Option 0 Internal | | Option 3 External | Function |
|-------------------|--------|-------------------|----------------|
| Pin | Colour | | |
| 1 | Red | Red | Supply +ve |
| 2 | Yellow | Orange | I2C SDA |
| 3 | Green | Black | I2C SCL |
| 4 | Blue | White | 0 V |
| 5 | Orange | Yellow | Do not Connect |
| 6 | Black | Blue | Do not Connect |
| - | - | Screen | Case |

General Certifications

RoHS 2011/65/EU

CRN Certified OF 13650.513467890YTN for pressure ranges up to and including 100 bar

CE Conformity

ATEX 2014/34/EU (Optional)

EMC Directive 2014/30/EU (External version only)

BS EN 61326-1:2013

BS EN 61000-6-1: 2007

BS EN 61000-6-3: 2007 + A1:2011

Hazardous Area Approvals

External Version (Apparatus)

ATEX  II 1G

IECEX Ex ia IIC T4 Ga (-40°C ≤ Ta ≤ 80°C)

Internal Version (Component)

ATEX  II 1G

IECEX Ex ia IIC Ga

Ordering Information

1) Select part number

Main Product Family

DPS

Product Diameter and Material

50 25mm Stainless Steel

Electrical Connection

0 None (flying leads)

3 Polyurethane cable Note 1

Electronics Option

D Digital I2C bus

Compensated Temperature Range

TC -40° to +85°C (-40° to +185°F)

Accuracy

A3 Premium

Calibration

CC Full Thermal

Hazardous Area Certification

H0 None

H1 IECEX/ATEX Intrinsically Safe 'ia' Group IIC

Pressure Connector

PA G1/4 Female

PB G1/4 Male Flat

PE 1/4 NPT Female

PF 1/4 NPT Male

PG 1/8 NPT Male

DPS 50 - D - TC - A3 - CC - - -

Ordering Notes

Note 1: Cable length 3 m

Typical Order Example:

DPS503D-TC-A3-CC-H1-PF 20 bar gauge

Mechanical Drawings

Internal Version

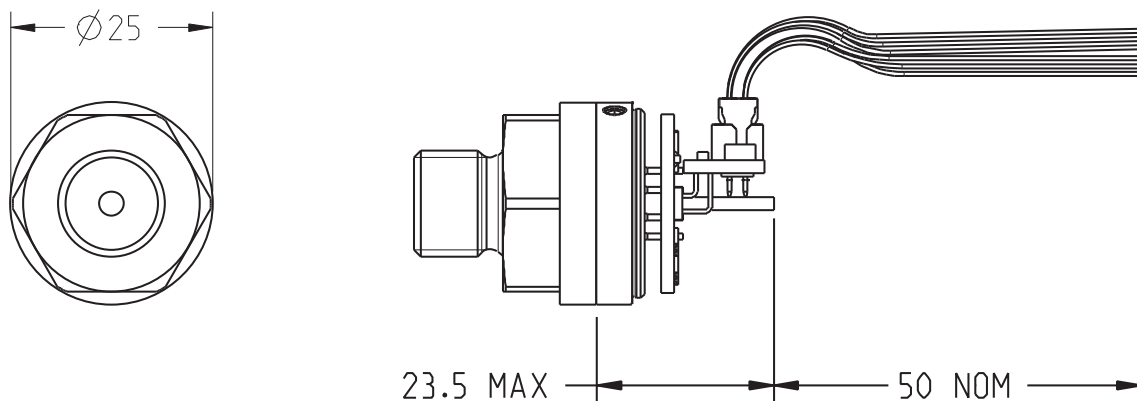

GAUGE SENSOR WITH PB PRESSURE CONNECTOR SHOWN

External Version

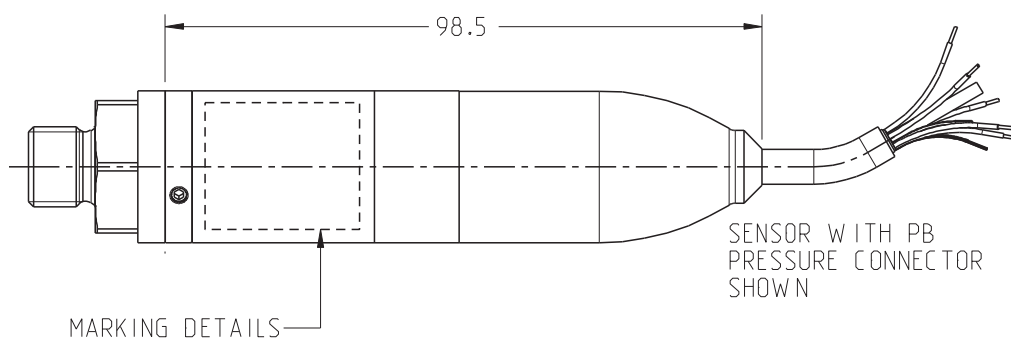

Notes:

(1) All dimensions in millimetres.

bhge.com

© 2015 Baker Hughes, a GE company - All rights reserved.

Baker Hughes reserves the right to make changes in specifications and features shown herein, or discontinue the product described at any time without notice or obligation. Contact your BHGE representative for the most current information. The Baker Hughes logo is a trade mark of Baker Hughes, a GE company. The GE Monogram is a trademark of the General Electric Company.

920-660B